

# TWIST - TONY

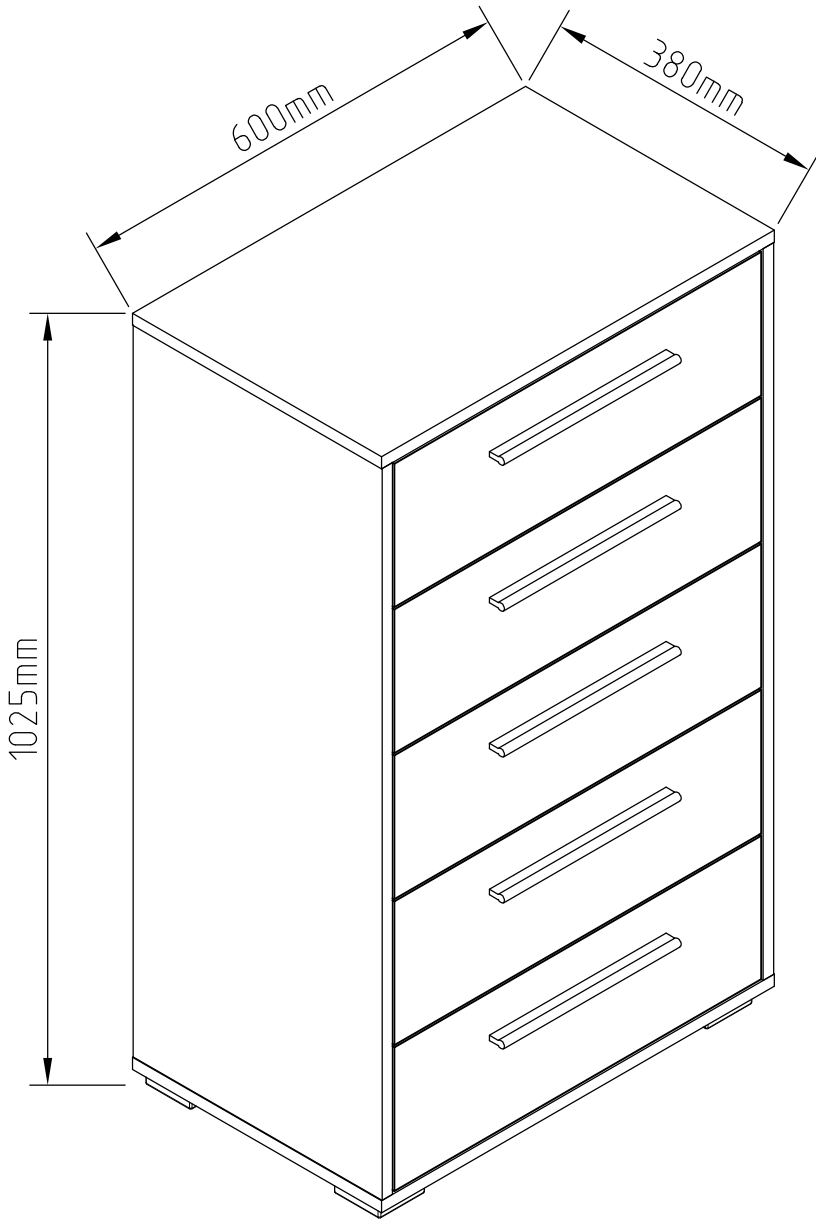







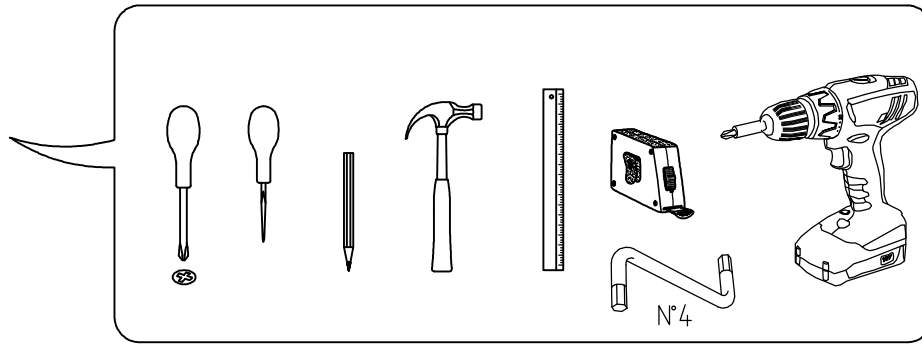
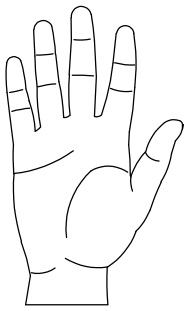

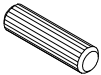

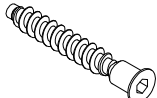
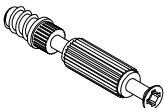
## CHEST OF DRAWERS 60

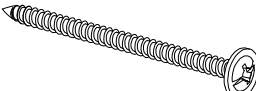
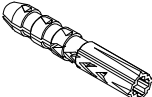

# TWIST - TONY

## chest of drawers 60

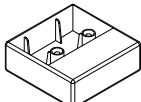
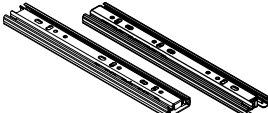

 <b>A1</b> 8*30mm x52	 <b>B</b> x14	 <b>B1</b> 6,3*50mm x14
 <b>C1</b> 6*43mm x18	 <b>D</b> $\phi$ 20mm x18	 <b>D1</b> 15/16 x18
 <b>E6</b> 3,5*16 x40	 <b>E14</b> 4*25mm x15	 <b>E16</b> 4*35mm x8
 <b>E-2</b> 4,2*16mm x4	 <b>E-5</b> 4,2*65mm x1	 <b>H5</b> 8*50mm x1
 <b>H7</b> x1	 <b>I9</b> x5	 <b>K4</b> x4
 <b>M2</b> L-350mm x5	 <b>O8</b> L-966 mm x1	 <b>R3</b> 1.4*25mm 0.070kg

# TWIST - TONY

## chest of drawers 60

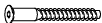
No	a*b	x	N°→...
1L	968x380	x1	2/3
1R	968x380	x1	2/3
2	600x380	x1	1/3
3	600x380	x1	1/3
4	566x60	x2	1/3
5	560x190	x2	3/3
6	560x190	x2	3/3
7	560x190	x1	3/3
8L	350x120	x5	1/3
8R	350x120	x5	1/3
9	508x120	x5	2/3
10	537x353	x5	1/3
11	996x296	x1	2/3
12	996x296	x1	2/3
		x1	1/3

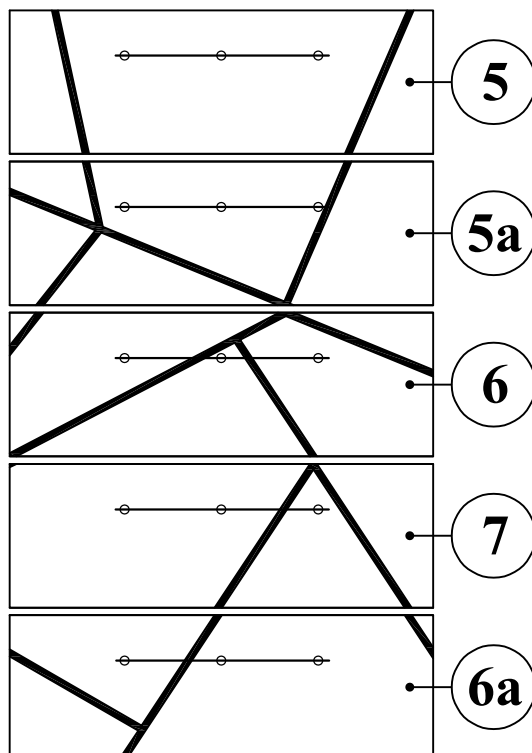

# TWIST - TONY

## chest of drawers 60

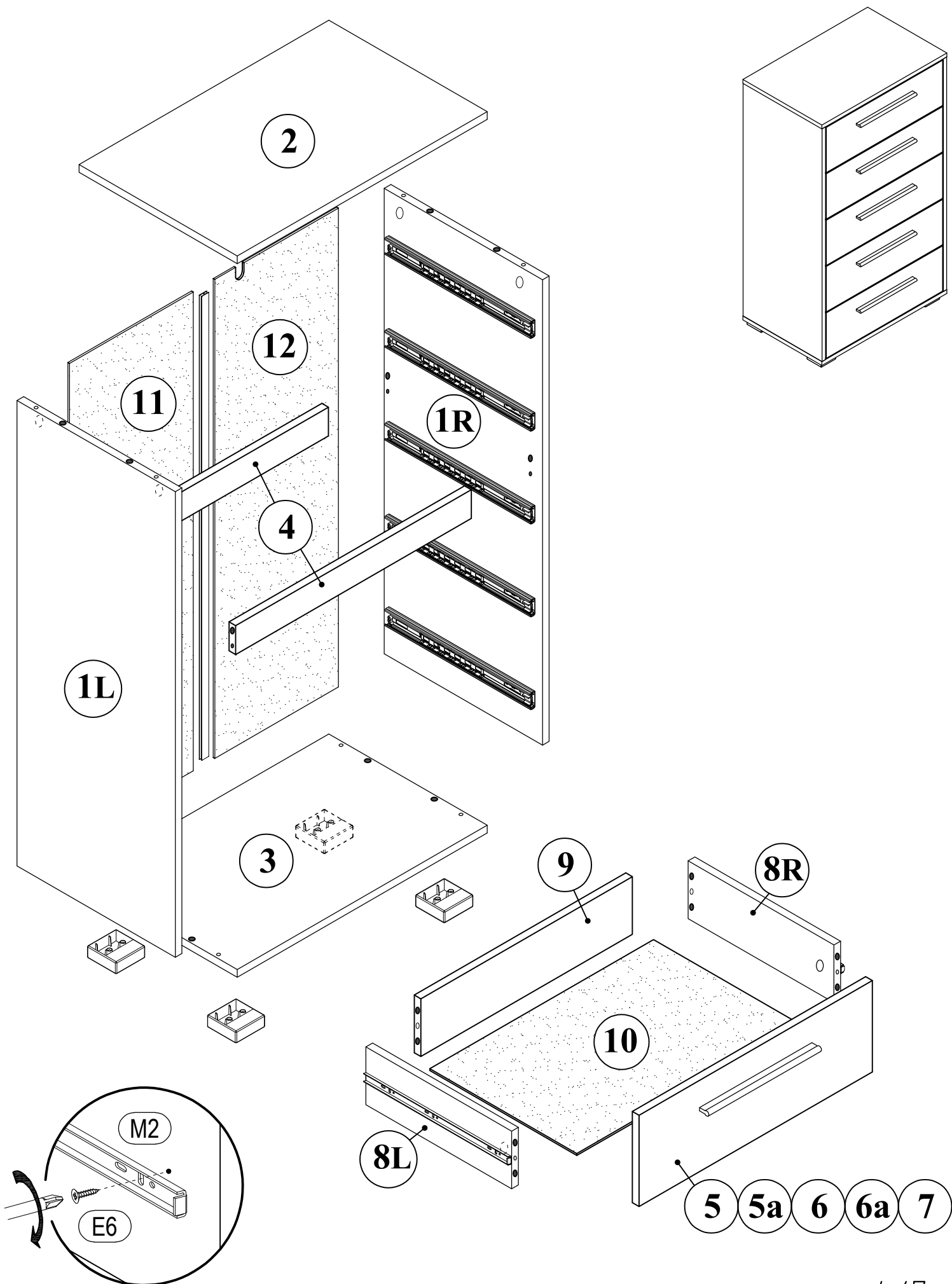

# TWIST - TONY

## chest of drawers 60

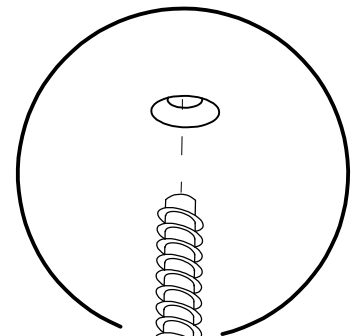
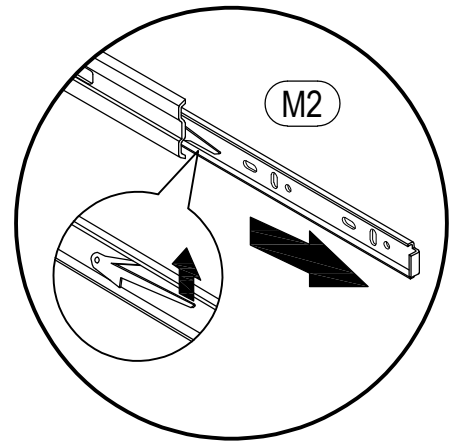
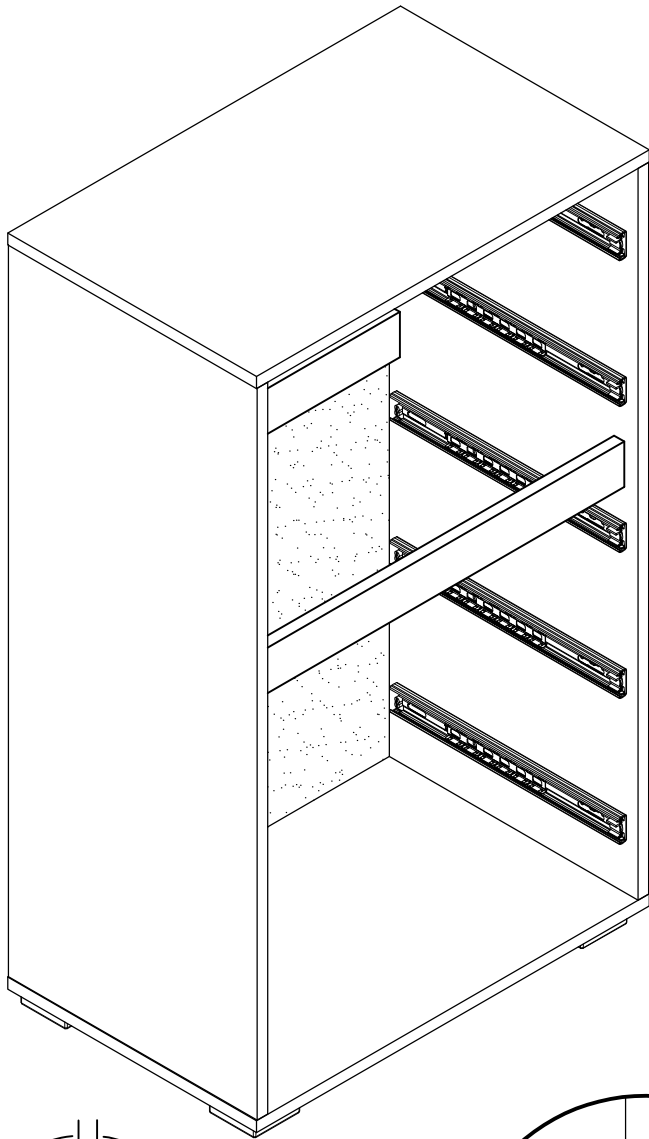

B1

R4

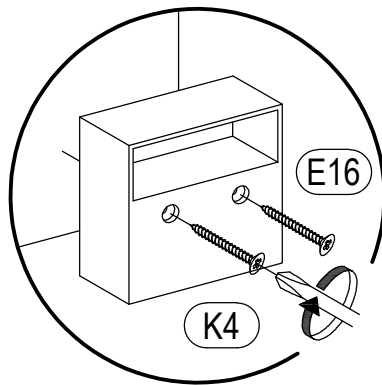
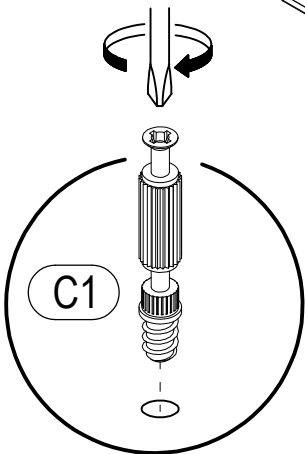
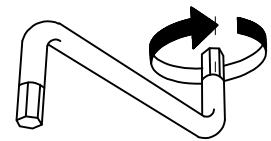

E16

K4

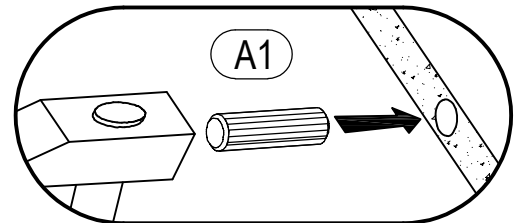

A1

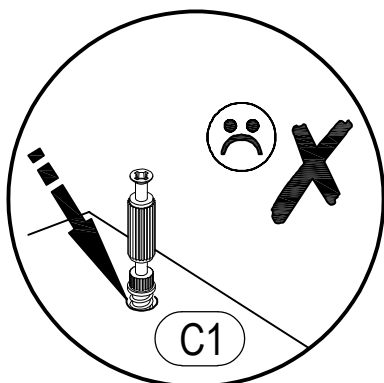

C1

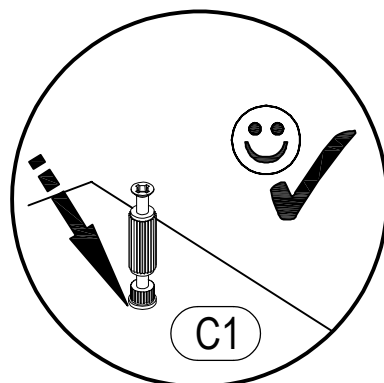

C1

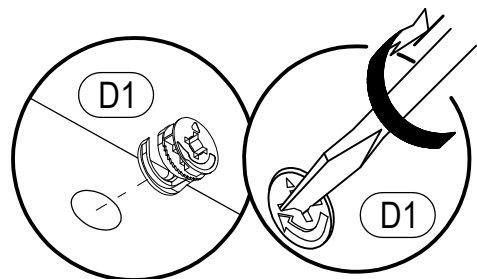

D1

D1

# TWIST - TONY

## chest of drawers 60

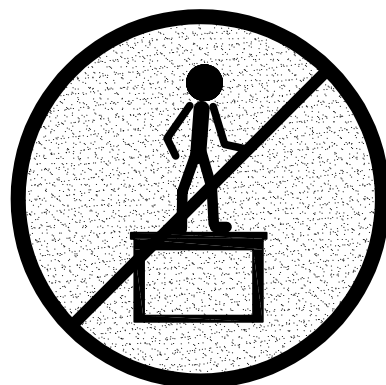
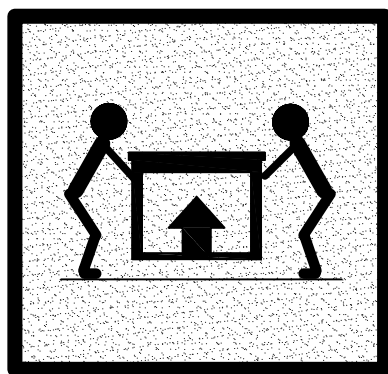
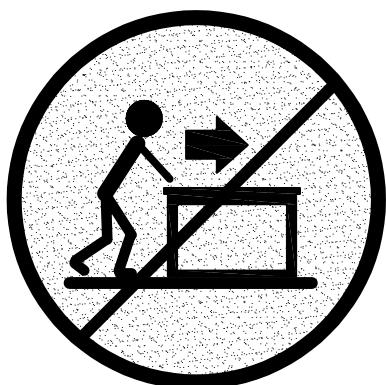
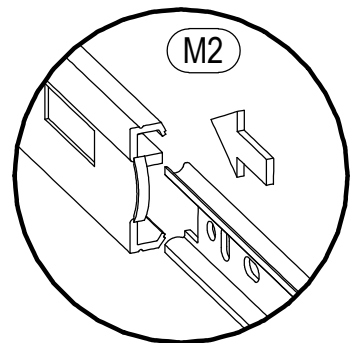
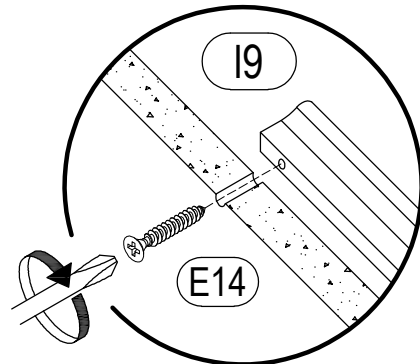
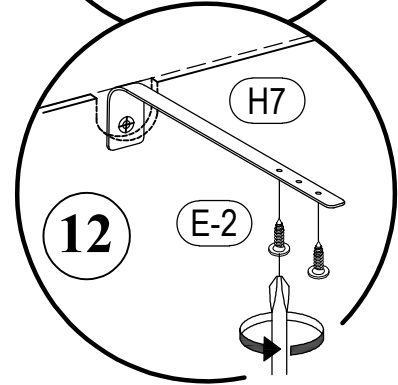
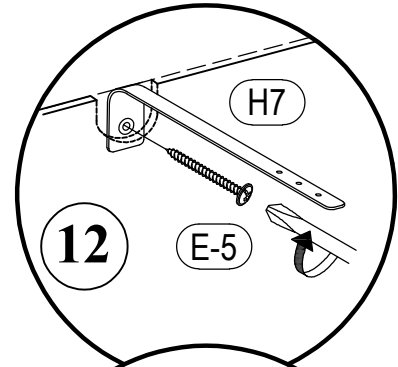
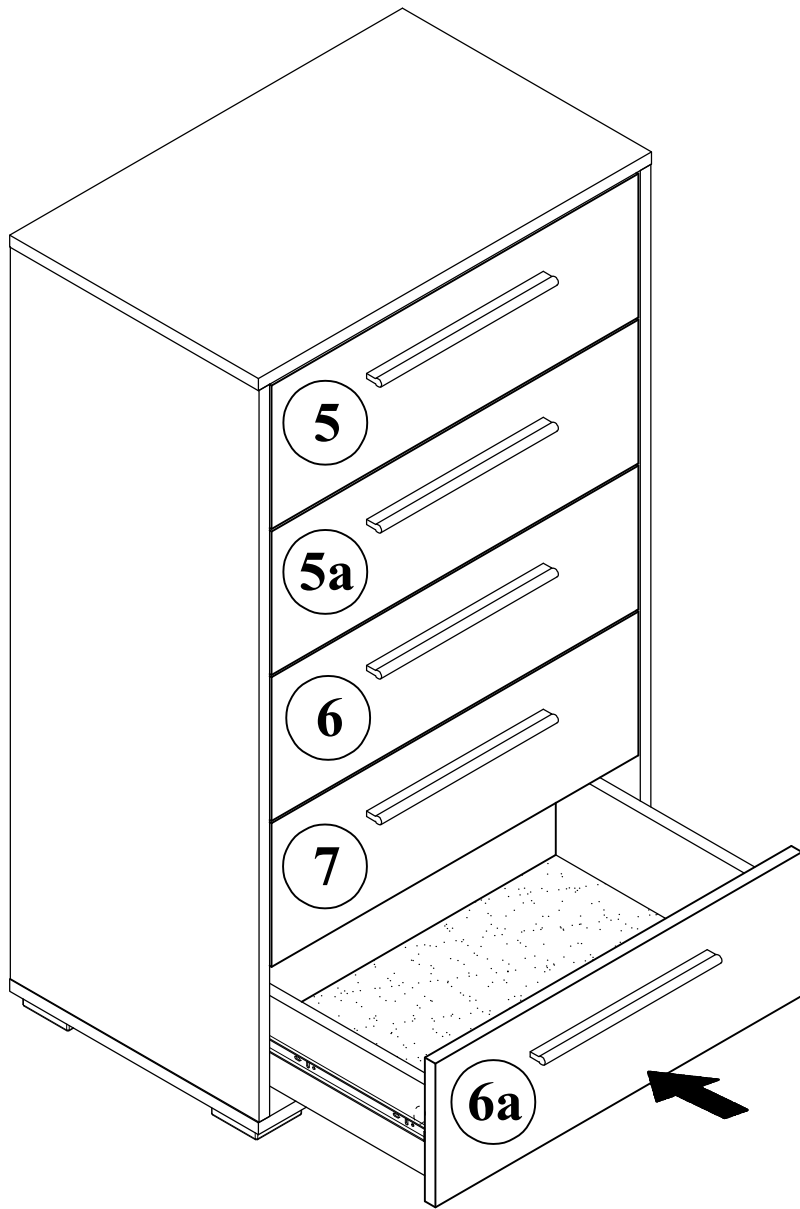

# TWIST - TONY

chest of drawers 60

