

PALMIRA

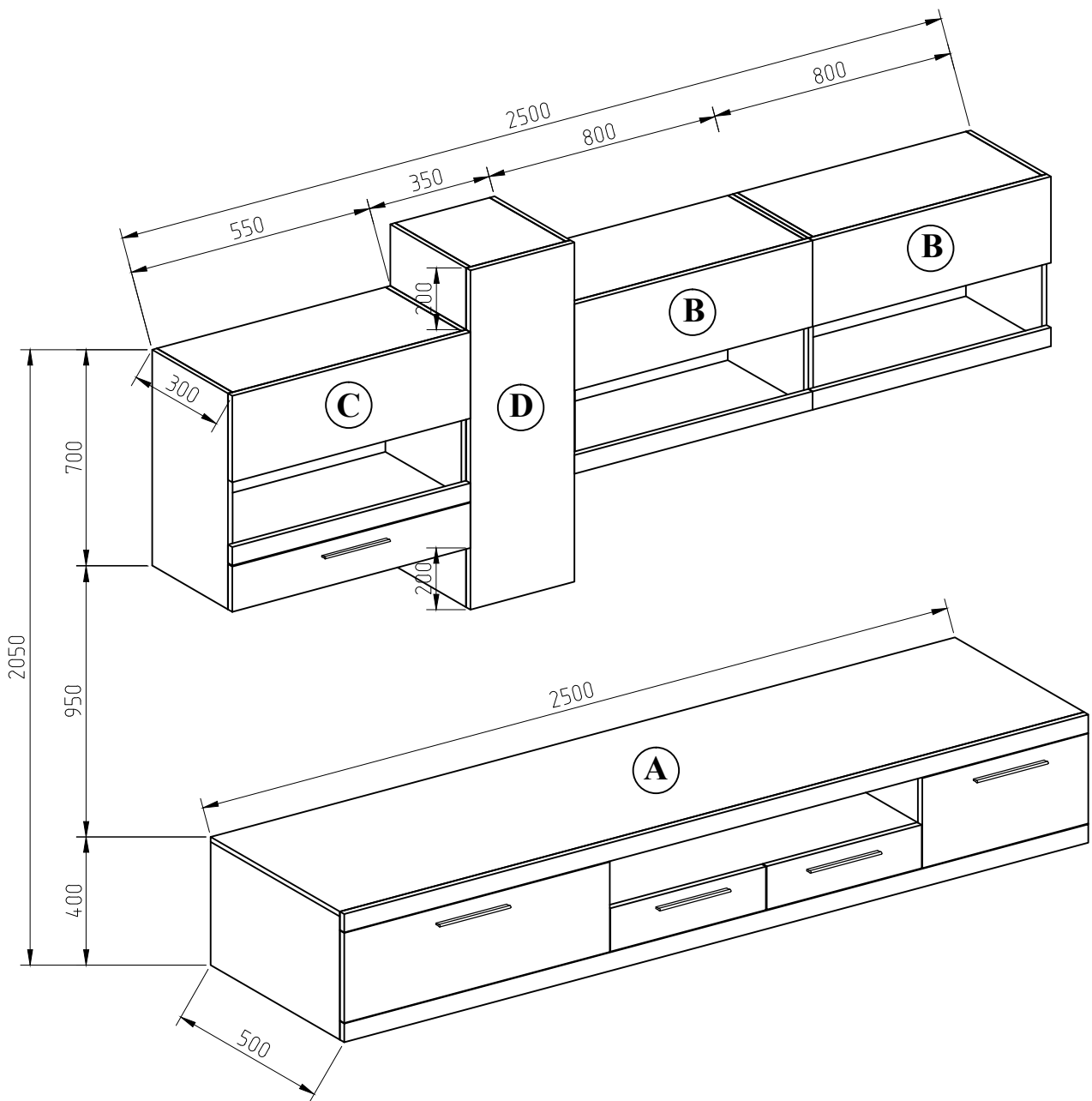

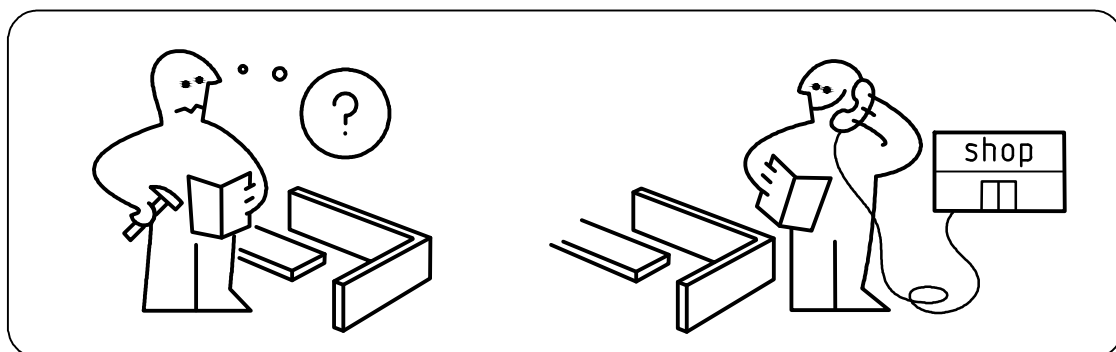
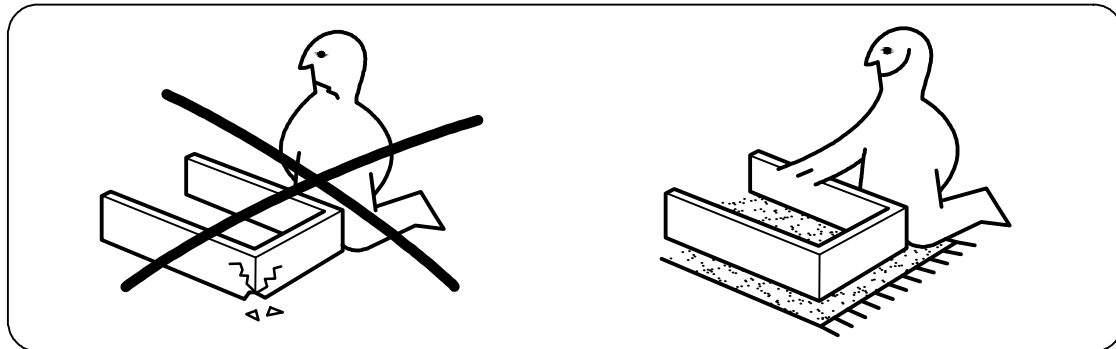
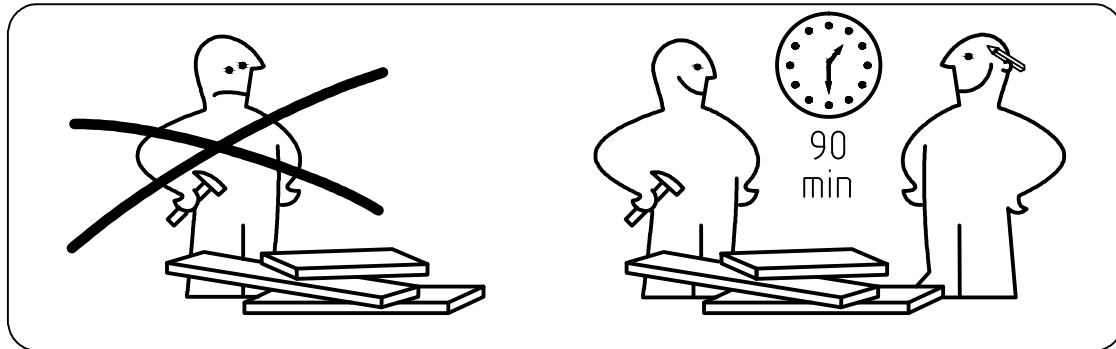
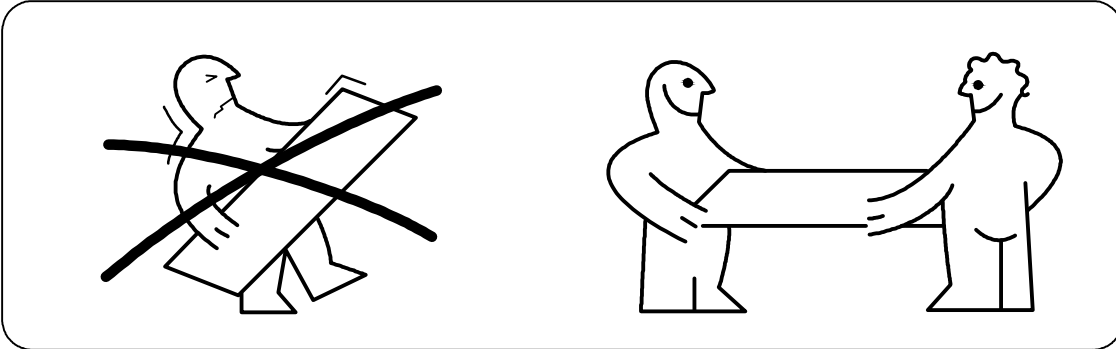
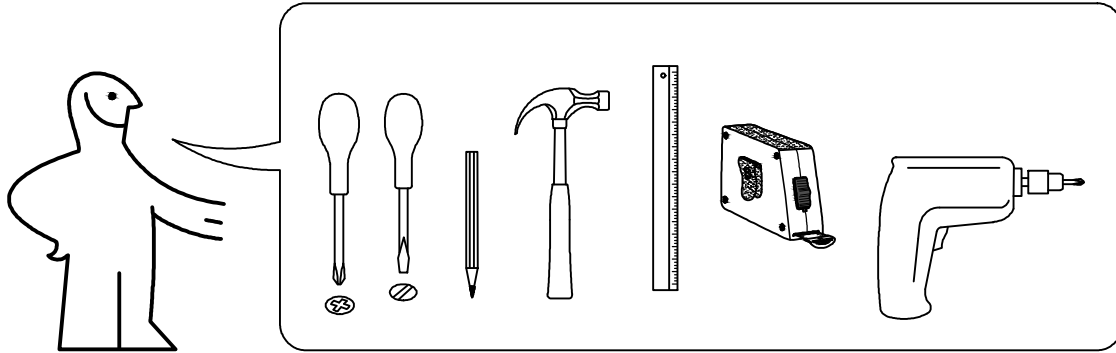
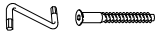

A

	a*b	x	Nº→...
1R	384x484	x1	
1L	384x484	x1	
2R	384x484	x1	
2L	384x484	x1	
3	176x484	x1	
4	2500x484	x1	
5	1018x484	x1	
6	868x484	x1	
7	550x484	x1	
8	1018x80	x2	
9	450x100	x4	
10	443x100	x2	
11	2500x60	x2	
12	888x274	x1	
13	570x274	x1	
14	515x143	x2	
15	2496x396	x1	
16	452x471	x2	
		x1	

C

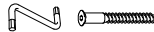
	a*b	x	Nº→...
1R	700x284	x1	
1L	700x284	x1	
2	518x284	x4	
3	550x60	x1	
4	280x544	x1	
5	250x90	x2	
6	460x90	x1	
7	145x544	x1	
8	253x488	x1	
9	696x546	x1	
		x1	



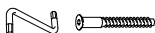







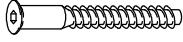

B

	a*b	x	Nº→...
1R	550x284	x1	
1L	550x284	x1	
2	768x284	x3	
3	800x60	x1	
4	280x794	x1	
5	546x796	x1	
		x1	

D

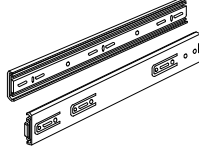
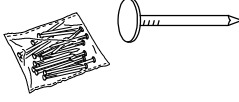
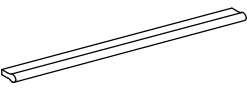
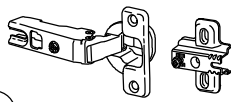

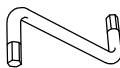

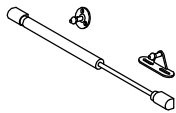
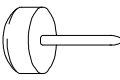

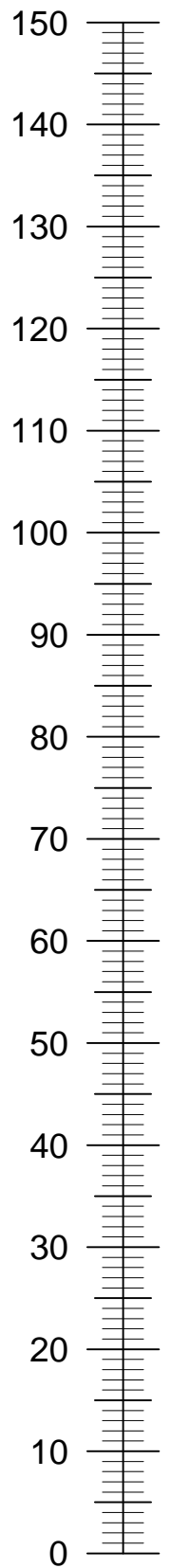

	a*b	x	Nº→...
1R	1100x284	x1	
1L	1100x284	x1	
2	318x284	x4	
3	1096x346	x1	
4	1096x346	x1	
		x1	

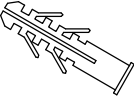
A

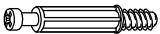
 <p>A1 8*30mm x34</p>	 <p>B x24</p>	 <p>B1 6,3*50mm x24</p>
 <p>C1 5*30mm x30</p>	 <p>D x30</p>	 <p>D1 16mm x30</p>
 <p>U3 x4</p>	 <p>E7 3,5*27mm x12</p>	 <p>M2 x2</p>
 <p>Q1 1.4*25mm 0.03kg</p>	 <p>I9 x4</p>	 <p>L1 x4</p>
 <p>F1 6,3*13mm x4</p>	 <p>P1 x1</p>	 <p>E3 3.5*16mm x44</p>
 <p>N3 x4</p>	 <p>K1 x8</p>	

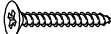
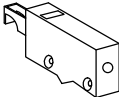
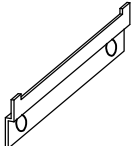
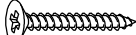
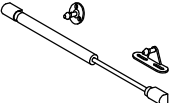
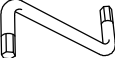

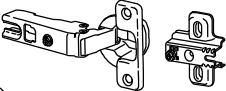



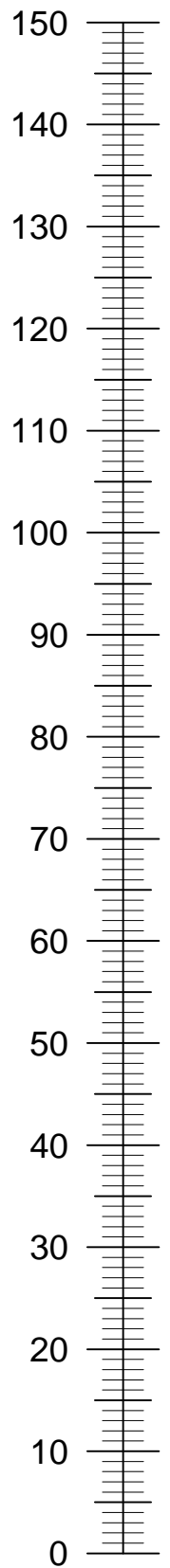



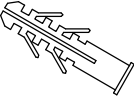

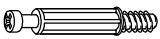
B x2

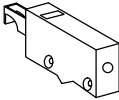
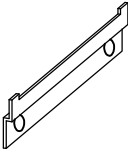
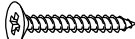
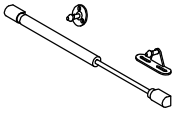
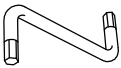
 A1 8*30mm x24	 H6 10*50mm x8	 D1 16mm x32
 C1 5*30mm x32	 D x32	 E9 4*30mm x8
 N1 x4	 O4 x4	 E20 6*60mm x8
 N3 x4	 P1 x1	 E3 3.5*16mm x28
 L1 x4	 F1 6,3*13mm x8	 U3 x4

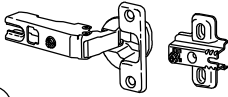

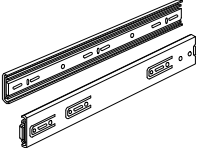

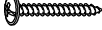

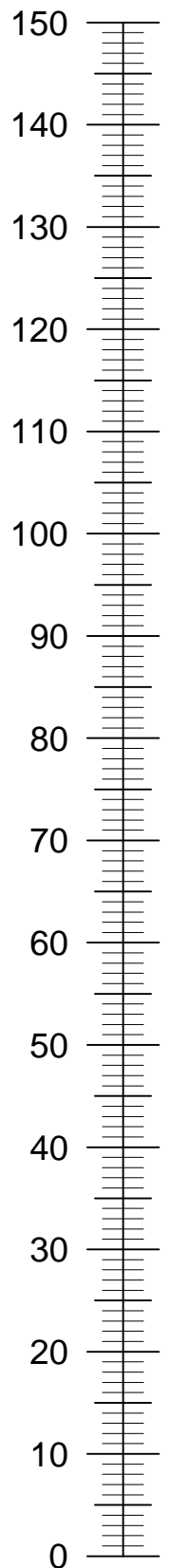



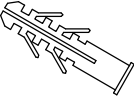

C

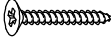
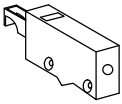
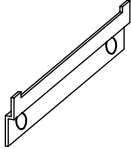
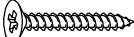
 A1 8*30mm x22	 H6 10*50mm x4	 D1 16mm x22
 C1 5*30mm x22	 D x22	 E9 4*30mm x4
 N1 x2	 O4 x2	 E20 6*60mm x4
 N3 x2	 P1 x1	 U3 x2
 L1 x2	 F1 6,3*13mm x4	 M2 x1
 E3 3.5*16mm x22	 I9 x1	 E7 3,5*27mm x3

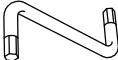

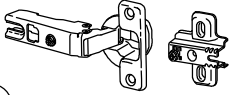
D

 A1 8*30mm x16	 H6 10*50mm x4	 D1 16mm x16
 C1 5*30mm x16	 D x16	 E9 4*30mm x4
 N1 x2	 O4 x2	 E20 6*60mm x4
 F1 6,3*13mm x6	 P1 x1	 E3 3,5*16mm x6
 L1 x3	 U3 x2	

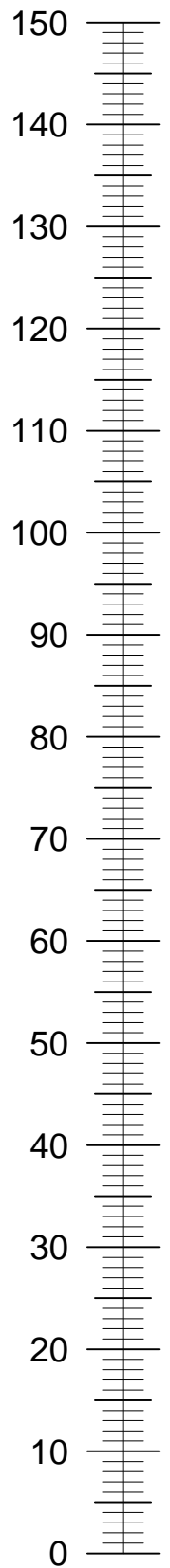

PALMIRA

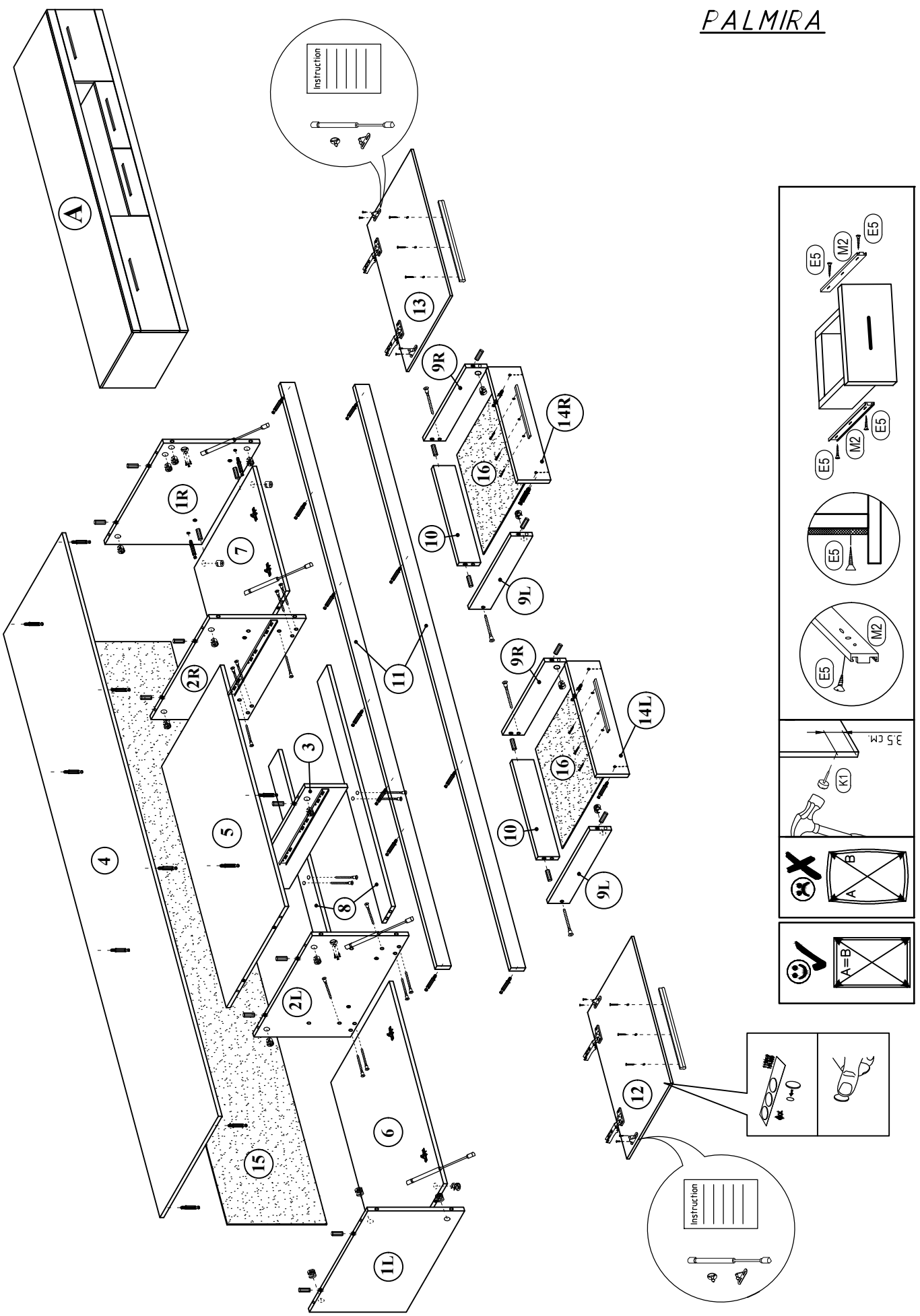

Palmira

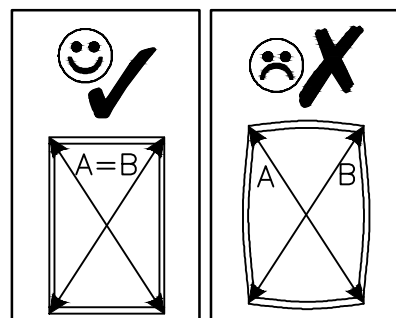
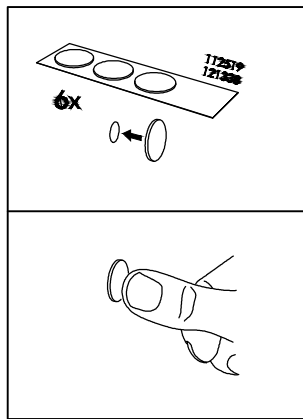
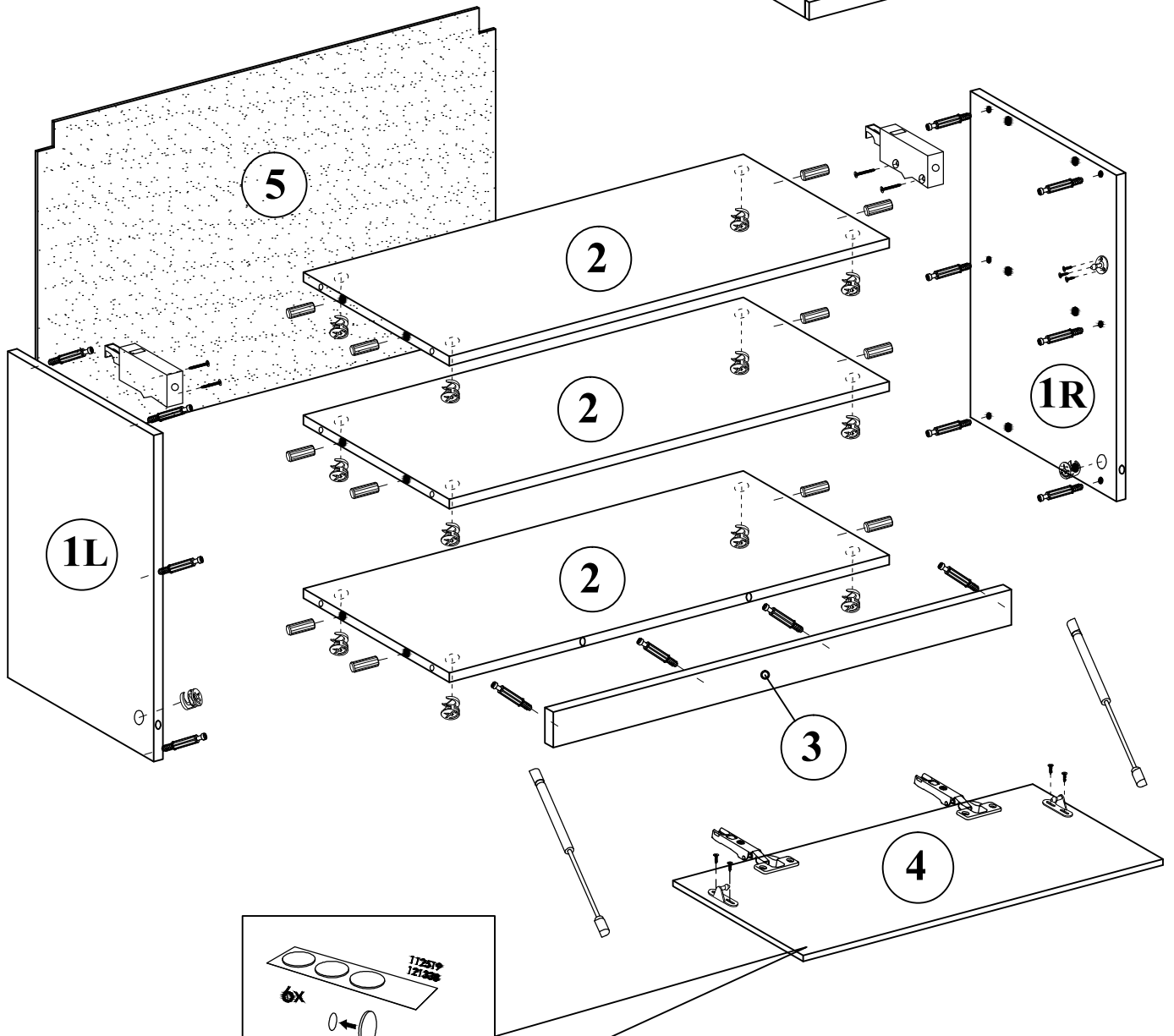
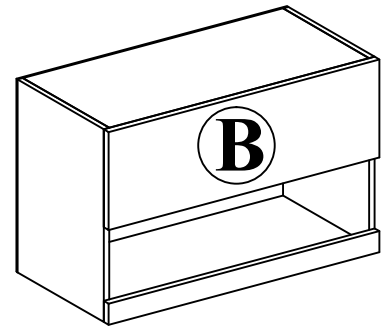

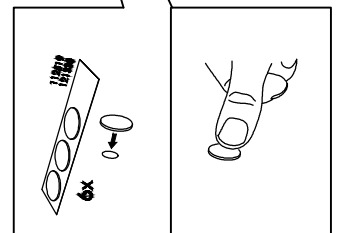
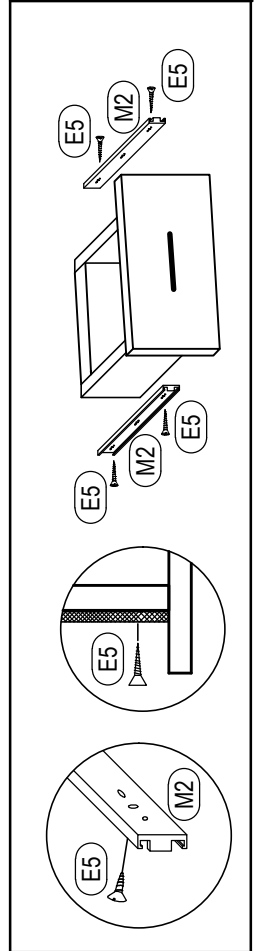
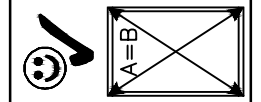
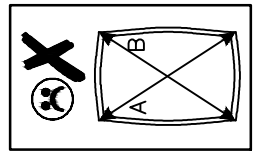
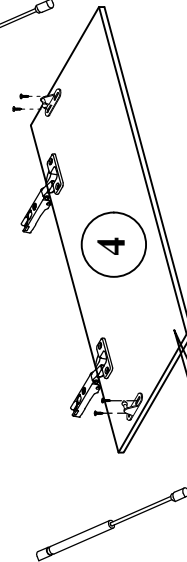
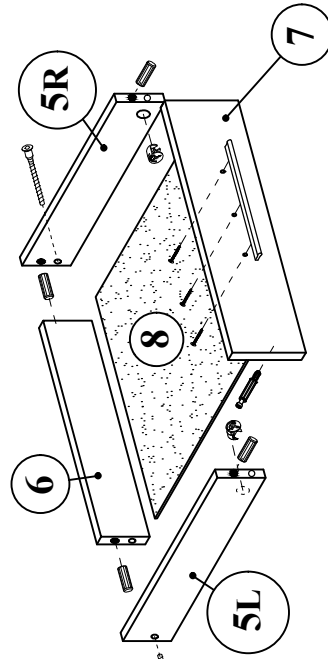
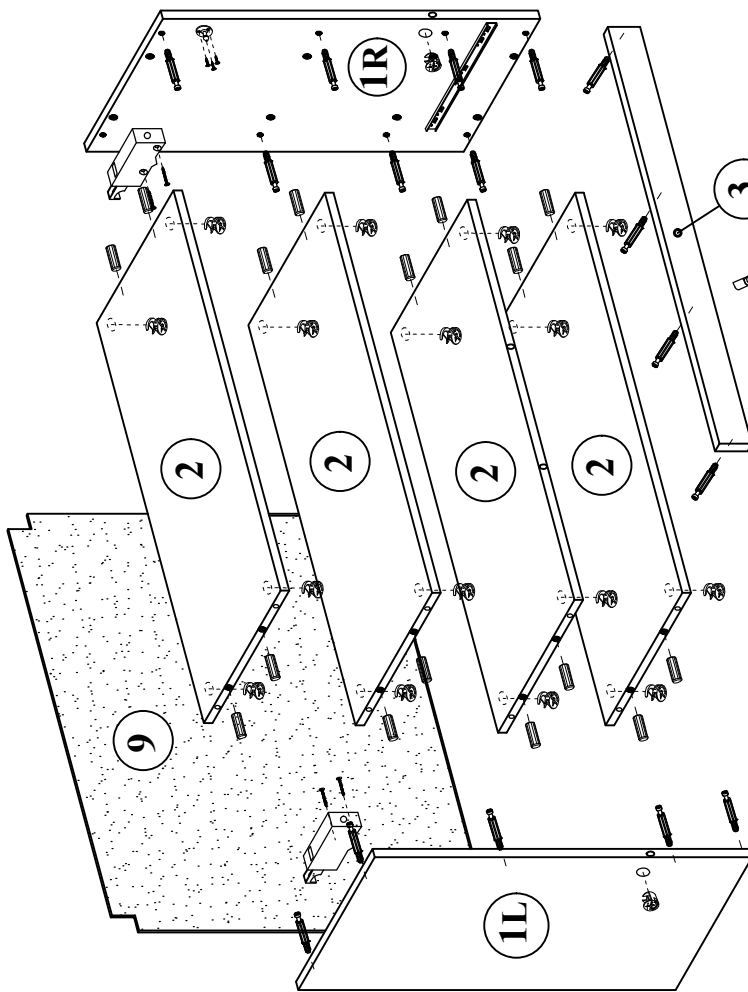
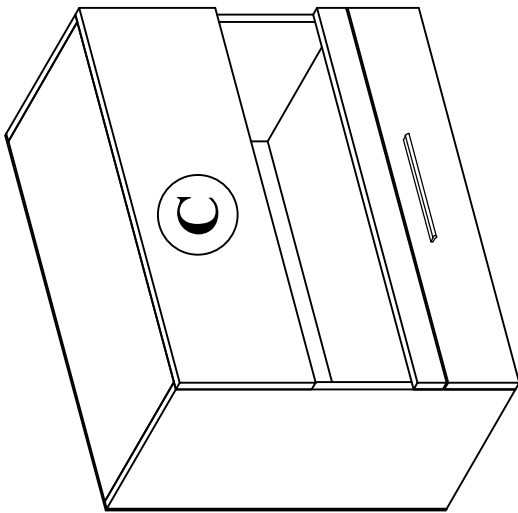

Palmira

